

Application Note #48

SC1000 System Controller Used for Automating Radiated Immunity Testing

By: Jason Smith, Applications Engineer Supervisor & Pat Malloy, Senior Applications Engineer

Systems designed to test for RF susceptibility or immunity contain a number of interconnected RF devices. By necessity, the majority of these test systems are configured as dynamic hardware solutions that address more than one of the ever changing EMC standards. Even manufacturers that have the luxury of only having to test to one EMC standard have discovered that mandated test levels and frequencies tend to increase over time, which impacts the selection of system rf devices. Considering the complexity of the newer EMC standards coupled with the complexity of the Equipment Under Test (EUT), the mechanics of simply “running” a standard test can be daunting. While theoretically one can conduct the required immunity tests manually, the amount of time and effort involved are so staggering, manual operation is only feasible when initially configuring a test system, when trouble shooting a system malfunction, or when very unique tests are required. The only viable option to this testing dilemma is automating the test by using a software driven RF test system controller that provides signal routing switch matrices. While productivity is increased markedly as the result of a significant decrease in the time required to perform EMC tests, a major side benefit of automation is repeatability. Aside from providing more accurate test results in a fraction of the time required to operate manually, repeatability is the single most significant characteristic of an automated system.

AR RF/Microwave Instrumentation has developed the SC1000 series of RF test system controllers to address the need for flexible automated systems. The SC1000 can accommodate up to three signal generators, four power amplifiers, four directional couplers, four unique RF loads for broadband RF testing from DC to 40 GHz and either a spectrum analyzer or receiver for EMI emissions testing. The SC1000 responds to remote commands via IEEE-488 (GPIB) or RS-232 as well as manual input via the front panel. Four open collector outputs (current sinking w/ an available +24VDC/500mA) and a switchable +12VDC source are supplied for those applications not supported by the existing SC1000 hardware. A four line vacuum fluorescent display provides operational information useful during initial system setup as well as when operating manually and system interlock capability is provided. This application note details the various uses and configurations of the SC1000 series.

Benefits of automation

The SC1000 System controller has many features built into its design that provide considerable savings in time and cost resulting in a significant increase in overall productivity.

- One of the biggest cost and time savers is the ability to automatically switch one power meter with two power heads to monitor up to four dual directional couplers. The alternative manual approach requires the use of four dual channel power meters with eight power heads permanently attached to the directional couplers or just use one power meter and physically move the power heads between the directional couplers each time frequency bands are switched. Since directional couplers are often inconveniently located for manual switching, this latter approach can be quite cumbersome.
- The trend toward higher frequency testing has mandated the use of expensive, high quality, low loss RF cables to reduce signal attenuation. Unlike standard RF cables, precision low loss

cables are susceptible to damage resulting from repeated movement and reconnections. Since the physical configuration of an automated system is fixed, the integrity and life expectancy of these expensive precision RF cables is assured.

- Since system reconfiguration between frequency bands is either reduced or totally eliminated, the focus of attention is shifted from the system setup to monitoring the EUT.
- Given that signal generators can be switched at will, the system can use generators designed for specific frequency ranges instead of a single expensive broadband generator that covers the entire frequency range. In this situation, a few narrower band signal generators may prove less costly than one that covers all test frequencies
- The SC1000 not only has internal coaxial switches, but it can control external RF switches with its series of open collector outputs. In some applications, external switches are necessary when very high power RF is involved or when it is desirable to physically move the position of a switch to a remote location removed from the system controller.
- By reducing or totally eliminating the need to manually change RF connections and switch antennas, a considerable amount of time is saved.
- Training of test engineers and technicians is greatly simplified by the use of automated setup routines. Automation provides more consistent test results over time, minimizing the impact that individual test personnel have on the test outcome. Repeatability is thus assured.
- Since the RF cables are not physically handled, they can be permanently configured in the most efficient manner, thus reducing lab clutter. Also, the absence of RF cables running across the floor and dangling from ceilings improves the operational safety of the lab.
- There is always a risk of equipment damage when conducting an EMC test if a damaged RF cable shorts out the system or if an incorrect load or no load is applied. Such setup errors are all but eliminated by automating the test system.

Basic RF immunity setup to test from 80 MHz – 1 GHz

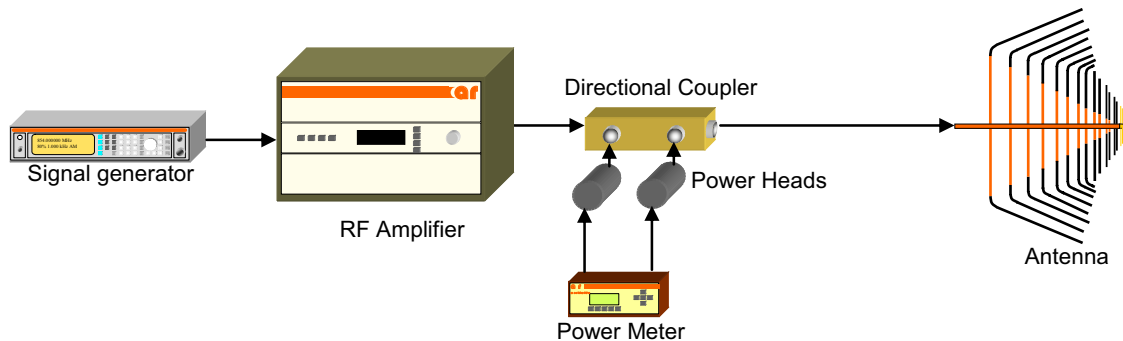

Figure 1

This is an example of an EMC test setup in its most basic form. Note that there is only one RF path and thus, no RF switching is required.

A typical RF immunity setup that accommodates the current mandate to test to higher frequencies (80 MHz – 6 GHz)

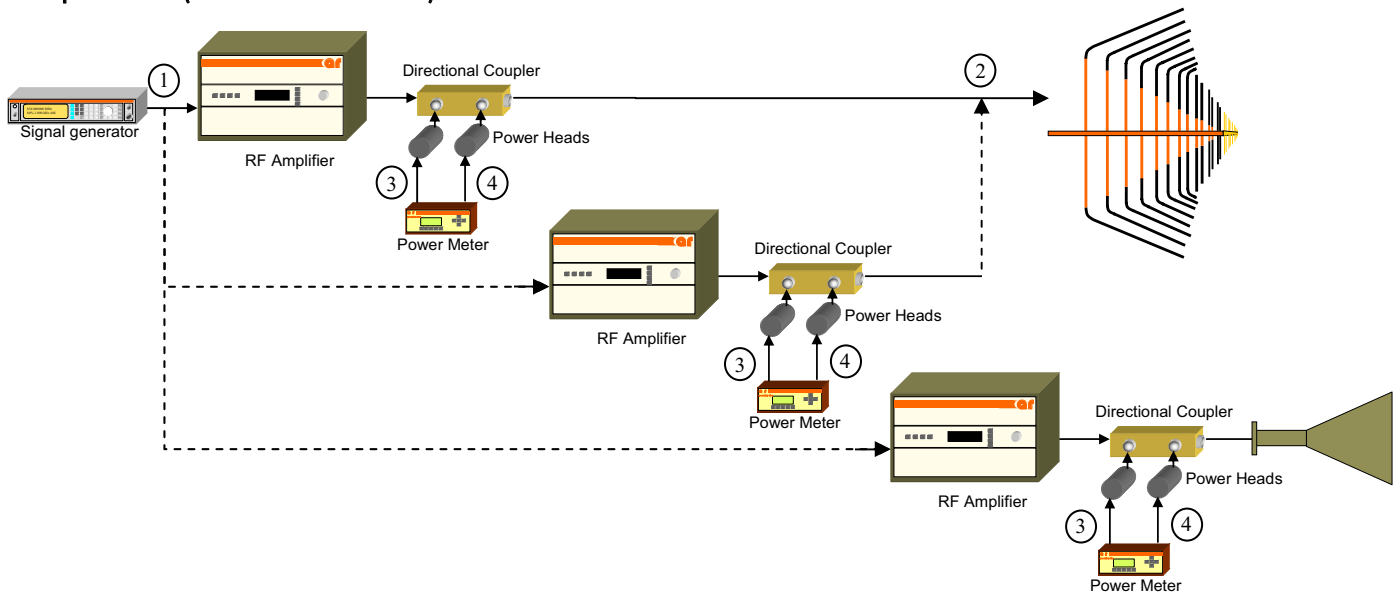

Figure 2

This diagram clearly demonstrates the need for additional RF devices to accommodate the higher frequency requirements of today’s EMC standards. The burden of additional test equipment as well as the requirement of multiple RF paths can be mitigated by the use of RF switching. At the very minimum, this system would benefit from the addition of two RF switches.

- ① The signal generator output can be routed to different RF amplifiers as required.
- ② The output of either of the two lower frequency amplifiers can be applied to the single log periodic antenna.

This is just the beginning of the possible productivity improvements an automated switching matrix provides. By adding just two more switches the requirement for three power meters with six power heads is reduced to a single power meter with two power heads.

- ③ Power head 1 on a single dual power meter can be switched between the forward power ports on all the directional couplers.
- ④ Power head 2 on the same dual power meter can switch between the reverse power port on all the directional couplers.

While four RF switches seem appropriate for the typical setup shown in Fig 2, additional switches are required for more complex systems. For example, if one or more amplifiers need to be switched between two antennas rather than just one, or if the EMC test includes a receiver or spectrum analyzer for emissions testing. In general, the more complex the test, the greater the need for RF switching. When configuring an RF system controller, it is best to think ahead and plan for all possible test scenarios to insure that all conceivable EMC tests can be fully automated.

Designing an RF switch matrix

The design of an RF switch matrix is directly influenced by the RF equipment that is to be switched and is limited by the specs of the coaxial switches selected. The key parameters are frequency range, Max RF power rating, and insertion loss.

How RF device's impact on the RF switch matrix...

Signal generator – Power is not a concern with this RF device since the output of a signal generator is low level RF. The important consideration is the frequency range of the generator.

RF Amplifier – Since RF amplifiers are used to amplify the low level RF output of the signal generator, both frequency range and power output must be considered. These specifications will dictate what RF switches can be used or even if a switch is available.

Antenna – While the frequency range and power handling capability are of importance since the antenna will be sized to accommodate both the frequency range and output power of the power amplifier. However these antenna characteristics do not directly affect the switching matrix.

Directional couplers – Since the switch matrix interfaces with the low power signal available at the coupling ports, the only specification that affects RF switch matrix design is frequency range.

From the above review of RF device impact on the RF switch matrix, the two specifications that are key in the selection of RF switches are frequency and power rating. RF switches are limited by their coaxial connectors which are specified for both maximum frequency of operation as well as their power handling capability. Power rating is generally provided at the lower frequency limits with a de-rating curve applied as operating frequency increases. In general, the power handling capability is proportional to connector size and the frequency capability is inversely proportional to size. For example, a relatively small SMA connector can operate up to 26 GHz with a power rating of 200 watts at 1 GHz while a larger standard Type N connector peaks out at 18 GHz but can tolerate 1000 watts at 1 GHz. The SC1000 system controller provides switching matrices from DC to 40 GHz at powers ranging from 25 – 1200 watts. Higher power and/or higher frequency applications are generally resolved by use of RF devices with waveguide connectors. Since waveguides are very frequency dependent with little overlap between sizes, RF switching is difficult or even unavailable in most cases. For these higher power, higher frequency applications it is best to dedicate antennas to each amplifier. When the frequency does not warrant waveguide connectors but the power exceeds the capabilities of the SC1000, larger external coaxial switches must be used. As noted above, the SC1000 has a number of open collector outputs and a switchable +12VDC signal that can be used to control these remote high power switches.

System Configuration Scenarios

Example 1 The goal is to setup a complete system for CE mark testing to meet:
IEC 61000-4-3 Radiated immunity @ 10V/m from 80 MHz to 6 GHz
IEC 61000-4-6 Conducted immunity @ 10V from 150 kHz to 80 MHz
CISPR 22 Emissions (See Fig. 3 for system diagram)

Selection of equipment...

Signal generators

1. SG6000 Broadband signal generator, 100 kHz – 6 GHz

Power amplifiers

1. 75A250A RF solid state amplifier, 75 Watts min, 150 kHz – 80 MHz

2. 150W1000 RF solid state amplifier, 150 Watts min, 80 kHz – 1 GHz
3. 25S1G4A Microwave solid state amplifier, 25 Watts min, 0.8 GHz – 4.2 GHz
4. 15S4G8 Microwave solid state amplifier, 15 Watts min, 4 GHz – 8 GHz

Dual directional couplers

1. DC2600A, 600 Watts Max, 10 kHz - 250 MHz
2. DC6180A, 600 Watts Max, 80 MHz - 1 GHz
3. DC7144A, 400 Watts Max, 0.8 GHz – 4.2 GHz
4. DC7350A, 350 Watts Max, 4 GHz – 8 GHz

Power meter and power heads

1. PM2002 dual channel power meter, 10 kHz - 40 GHz
2. PH2000 power head, 10 kHz - 8 GHz, (Two required)

Antennas and loads

1. AT5080 Log periodic antenna, 80 MHz – 1 GHz
2. AT4002A Horn antenna, 1 GHz – 4 GHz
3. AT4003A Horn antenna, 4 GHz – 6 GHz
4. IEC 61000-4-6 requires BCI probes and/or CDNs

Receiver

1. Model CER2018

System Controller

1. SC1000M1

Total equipment list summary

- 1 Signal generator
- 4 Power amplifiers
- 4 Dual directional couplers
- 1 Dual channel power meter
- 2 Power heads.
- 1 RF receiver
- 3 Antennas and a variety of BCI probes and CDNs depending on the EUT
- 1 System controller

The diagram in Fig 3 details the system described in Example 1.

Example 2 The goal in this example is to design a system to test for MIL-STD-461E RS103 compliance from 30 MHz – 40 GHz @ 200V/m (See Fig. 4 for system diagram)

Signal generators

1. Signal generator 1 (9 kHz – 1.2 GHz), Such as an SG1200
2. Signal generator 2 (200 MHz – 40 GHz)

Power amplifiers

1. 5000A250A, RF solid state amplifier, 5000 Watts min, 100 kHz – 250 MHz
2. 2000W1000A, RF solid state amplifier, 2000 Watts nominal, 80 MHz – 1 GHz
3. 400S1G4, Microwave solid state amplifier, 400 Watts min, 0.8 GHz – 4.2 GHz
4. 200T2G8A, Microwave TWT amplifier, 200 Watts min, 2.5 GHz – 7.5 GHz
5. 200T8G18A, Microwave TWT amplifier, 200 Watts min, 7.5 GHz – 18 GHz
6. 40T18G26A, Microwave TWT amplifier, 40 Watts min, 18 GHz – 26.5 GHz
7. 40T26G40A, RF TWT amplifier, 40 Watts min, 26.5 GHz – 40 GHz

Dual directional couplers

1. DC4250, 15 kW Max, 100 kHz - 250 MHz

2. DC6380, 3000 Watts Max, 80 MHz - 1 GHz
3. DC7154A, 400 Watts Max, 0.8 GHz – 4.2 GHz
4. DC7280A, 350 Watts Max, 2 GHz – 8 GHz
5. DC7450M1, 3000 Watts Max, 7.5 GHz – 18 GHz
6. DC7530, 300 Watts Max, 18 GHz – 26.5 GHz
7. DC7620, 200 Watts Max, 26.5 GHz – 40 GHz

Power meter and power heads

1. PM2002 dual channel power meter, 10 kHz - 40 GHz (Two required)
2. PH2000 power head, 10 kHz - 8 GHz, (Two required)
3. PH2010 power head, 30 MHz - 40 GHz, (Two required)

Antennas

1. AT2526, Log periodic antenna, 26 MHz – 250 MHz
2. AT4000A, Horn antenna, 200M Hz – 1 GHz
3. AT4510, Horn antenna, 1 GHz – 4 GHz
4. AT4520, Horn antenna, 2.5 GHz – 7.5 GHz
5. AT4004A, Horn antenna, 7.5 GHz – 18 GHz
6. AT4540, Horn antenna, 18 GHz – 26.5 GHz
7. AT4550, Horn antenna, 26.5 GHz – 40 GHz

System controller

1. SC1000M3
2. SC1000M4

The power levels required for this Mil-Std test exceed the power ratings of most commonly available RF switches. While available, RF switches capable of dissipating power well in excess of 10 kW are prohibitively large and quiet expensive. It is for this reason the RF switches shown in the system diagram (Fig. 4) are only used to switch low level input signals. An added advantage of directly connecting power amplifiers to dedicated antennas is the elimination of the insertion loss inherent in any RF switch. This is especially important when testing at elevated levels such as 200V/m.

Total equipment list summary for Example 2

- 2 Signal generators
- 7 Power amplifiers
- 7 Dual directional couplers
- 2 Dual channel power meters
- 4 Power heads
- 7 Antennas
- 2 System controllers

The system diagram in Fig. 4 shows the system configured to accommodate the criteria set forth in example 2. Note that two system controllers are combined to automate this large system.

System Controller SC1000M1

Setup Diagram

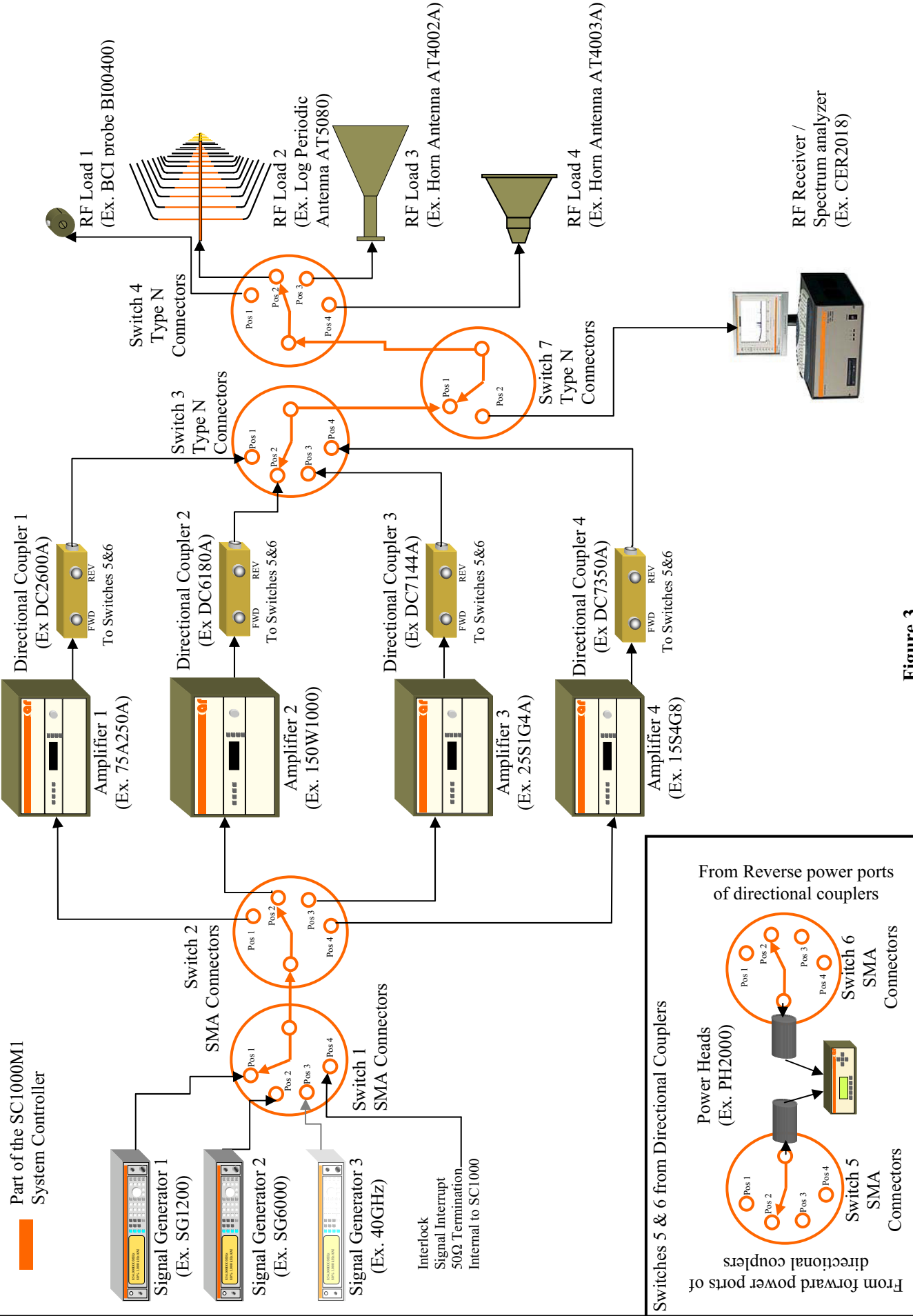

Figure 3

System Controller SC1000M3 & SC1000M4

Setup Diagram

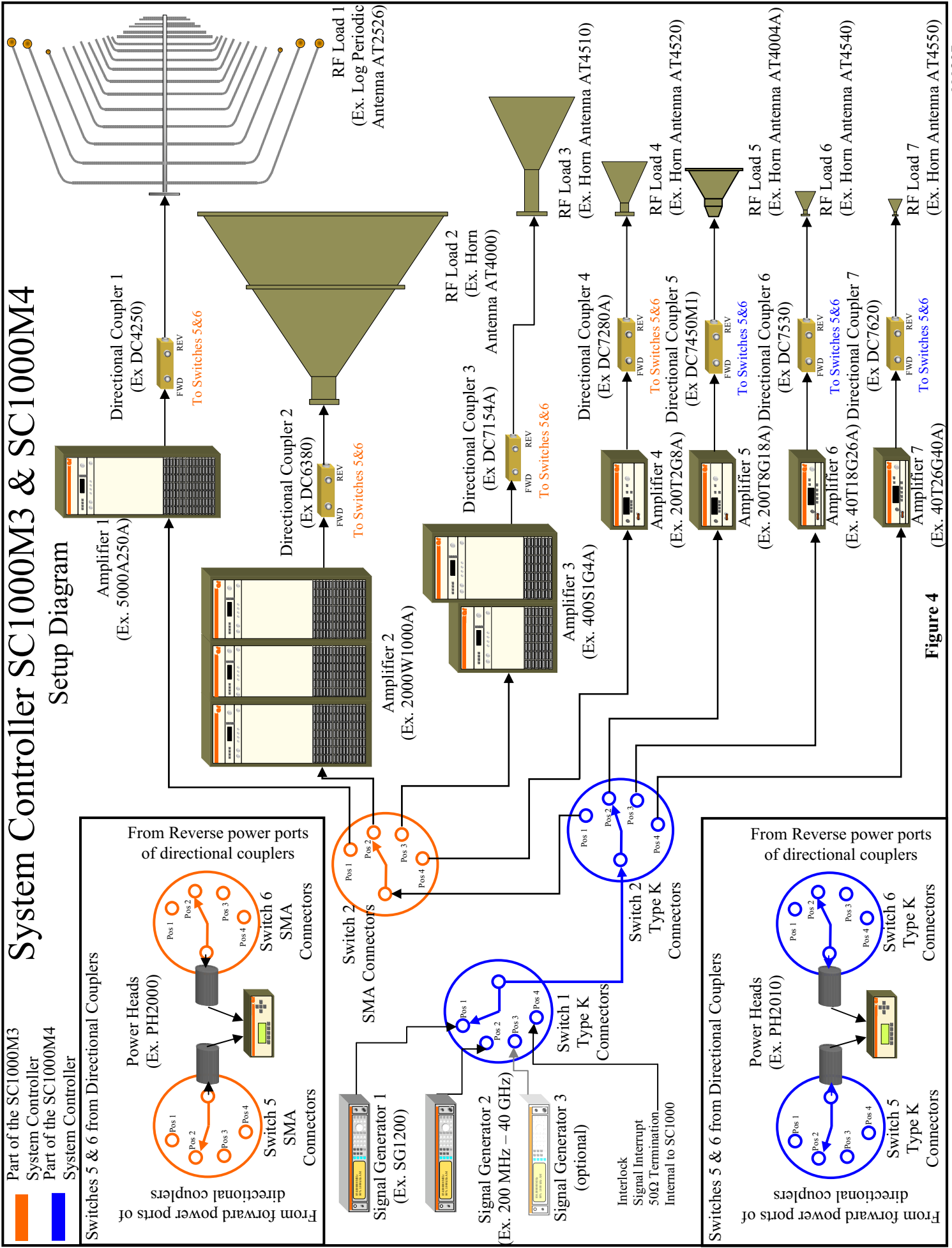

Figure 4

The SC1000 system controller discussed in this application note can be purchased in one of five different configurations that cover a wide range of testing requirements. Consult the configuration guide shown in Table 1 along with the switch characteristics shown in Figures 5 and 6 to determine the SC1000 model best suited for the specific task at hand.

SC1000 configuration guide

SC1000 Versions	Max # of signal generators	Max # of amplifiers	Max # of Loads	Ability to Switch in a receiver/spectrum analyzer	# of forward power ports can be switched to 1 power head	# of reverse power ports can be switched to 1 power head	Can work up to 40 GHz	Total # of switches
SC1000	3	4	4	No	4	NA	No	5
SC1000M1	3	4	4	Yes	4	4	No	7
SC1000M2	3	4	NA	No	4	NA	No	3
SC1000M3	3	4	NA	No	4	4	No	4
SC1000M4	3	4	NA	No	4	4	Yes	4

Table 1

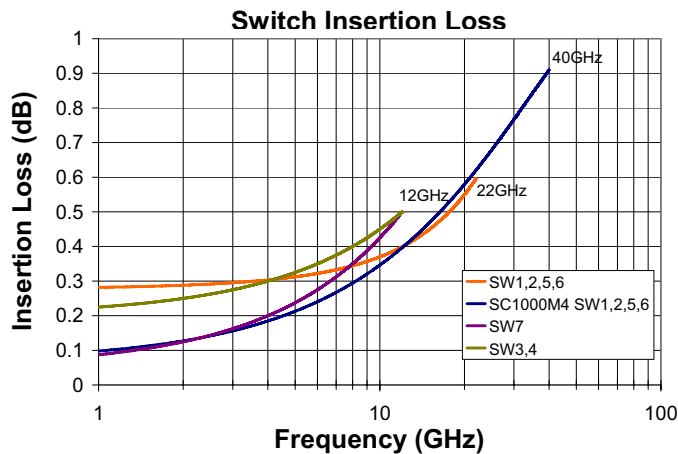

Figure 5

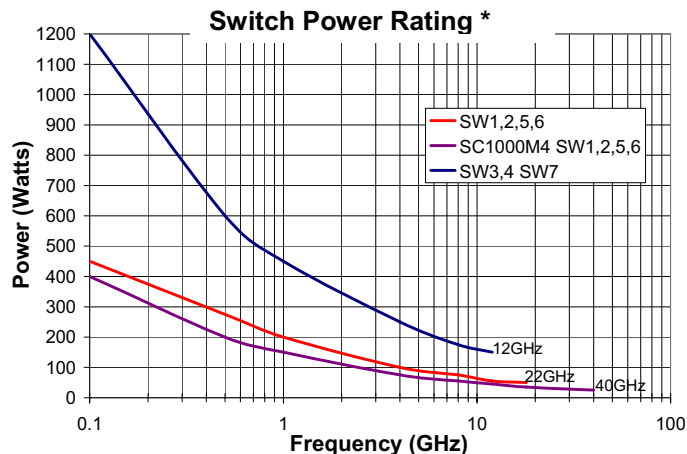

Figure 6

* Switch power rating is inversely proportional to VSWR. See the SC1000 specification sheet for power derating information.

This application note has identified the benefits of automating EMC test systems. While the focus has been on the AR RF/Microwave Instrumentation family of RF test system controllers, it must be noted that automated systems require system software to function. The versatile SC1000 will operate with customer supplied custom software or one of the "off-the-shelf" EMC test software packages from AR RF/Microwave Instrumentation. For questions regarding system software or system controllers, feel free to contact one of our application engineers at (800) 988-8181.