

APPLICATION NOTE #21
AR RF/MICROWAVE INSTRUMENTATION PRODUCTS THAT
PROVIDE 50 V/m CW OR PM AT A DISTANCE OF 1 METER ¹

The Amplifier / Antenna / Cell combinations shown in Table 1 provide various means of generating 50 V/m, CW or Pulse Modulated, inside a TEM Cell, between the elements of an E-field generator, or at a distance of one meter from a radiating antenna, from 10 kHz to 40 GHz. This table is used in conjunction with the enclosed product selection flow chart and system diagrams. The appropriate combination of products is determined by first noting the physical size of the Device Under Test (DUT). The size of the test object determines the appropriate path taken on the flow chart. Follow the path that accommodates the maximum expected DUT size.

As an example, to test a device 14 inches or less on a side across the entire frequency band from 10kHz to 40GHz, select items 8, 9, 10, 11, 12, 13 and 14. If the test object is larger than 14 inches on a side, items 1, 2, 3, 4, 5, 6, and 7 would be appropriate.

When testing small objects, a TEM cell offers an economical solution in that it is used in lieu of both a radiating antenna and a shielded enclosure. For a test object 4 inches or less in height, select items 15 and 16. If the DUT is 2 inches or less in height, then items 17 and 18 can be used.

To accurately determine field strength in the area of the DUT, a field monitor such as the AR RF/Microwave Instrumentation model FM7004 and an appropriate field probe are required. Contact the factory for specific recommendations.

50 V/m CW OR PM AT A DISTANCE OF 1 METER¹

ITEM ²	FREQUENCY	AMPLIFIER	ANTENNA or CELL	DUT PLACEMENT
1	10 kHz – 100 MHz	1000A100	AT5000M3	1 meter ³
2	100 MHz – 1 GHz	150W1000	AT1080	1 meter
3	1 GHz – 4 GHz	5S1G4	AT4510	1 meter
4	4 GHz – 8 GHz	20T4G18	AT4218	1 meter
5	8 GHz – 18 GHz	20T4G18	AT4218	1 meter
6	18 GHz – 26 GHz	40T18G26A	AT4640	1 meter
7	26 GHz – 40 GHz	40T26G40A	AT4650	1 meter
8	10 kHz – 100 MHz	75A250A	AT3100	Between Elements
9	100 MHz – 1 GHz	150W1000	AT1080	1 meter
10	1 GHz – 4GHz	5S1G4	AT4510	1 meter
11	4 GHz – 8 GHz	20T4G18	AT4218	1 meter
12	8 GHz – 18 GHz	20T4G18	AT4218	1 meter
13	18 GHz – 26 GHz	40T18G26A	AT4640	1 meter
14	26 GHz – 40 GHz	40T26G40A	AT4650	1 meter
15	10 kHz – 250 MHz	25A250A	TC3020A	Center of Cell
16	250 MHz – 375 MHz	10W1000C	TC3020A	Center of Cell
17	10 kHz – 250 MHz	25A250A	TC1510A	Center of Cell
18	250 MHz – 750 MHz	1W1000B	TC1510A	Center of Cell

Table 1

- ¹ The RF fields generated by the products recommended in this application note are either CW or pulse modulated, and occur at a distance of one meter unless otherwise noted. If the application requires amplitude modulation, additional amplifier power is required. Call Application Engineering at 800-933-8181 for details.
- ² The Item numbers match the Block numbers on the enclosed Product Selection Flow Chart.
- ³ There is little to no margin below 100 kHz. The DUT may need to be placed closer than 1m at these points.

50V/m CW or PM @ 1M* Amplifier/Antenna/Cell Selection Chart

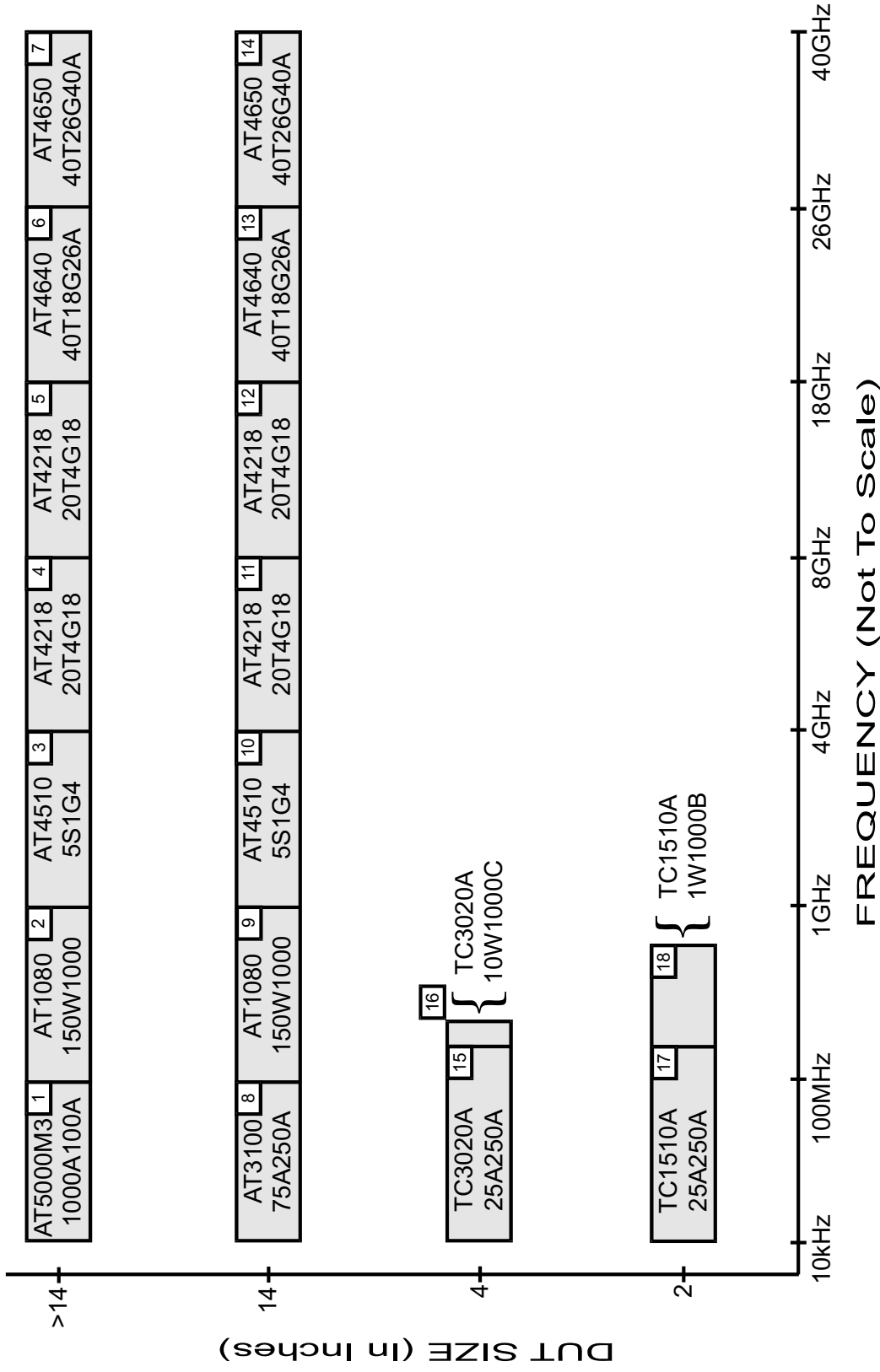

* The numbered cells represent either Amplifier / Antenna or Amplifier / Cell combinations. The actual distance from the field generator to the DUT may vary from 1 meter. See Table 1 for details.

Typical Pre-Compliance Radiated Immunity Test Systems

(Use in applications that call for "loop leveled" or "real-time leveled")

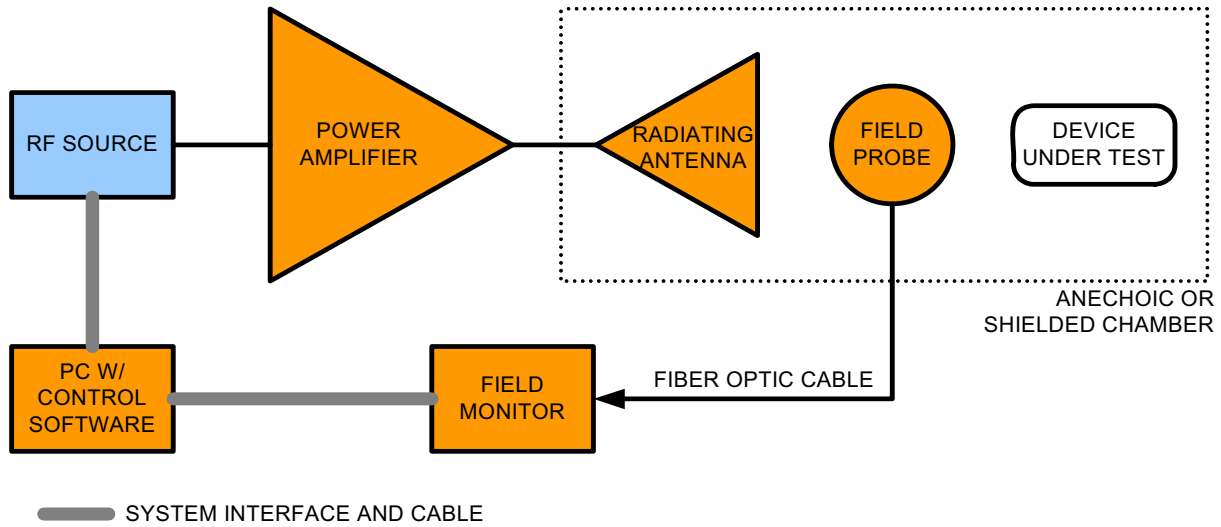

BASIC LOOP LEVELLED SYSTEM

Full Compliance Radiated Immunity Test Systems

(Use in applications that call for "substitution method" testing)

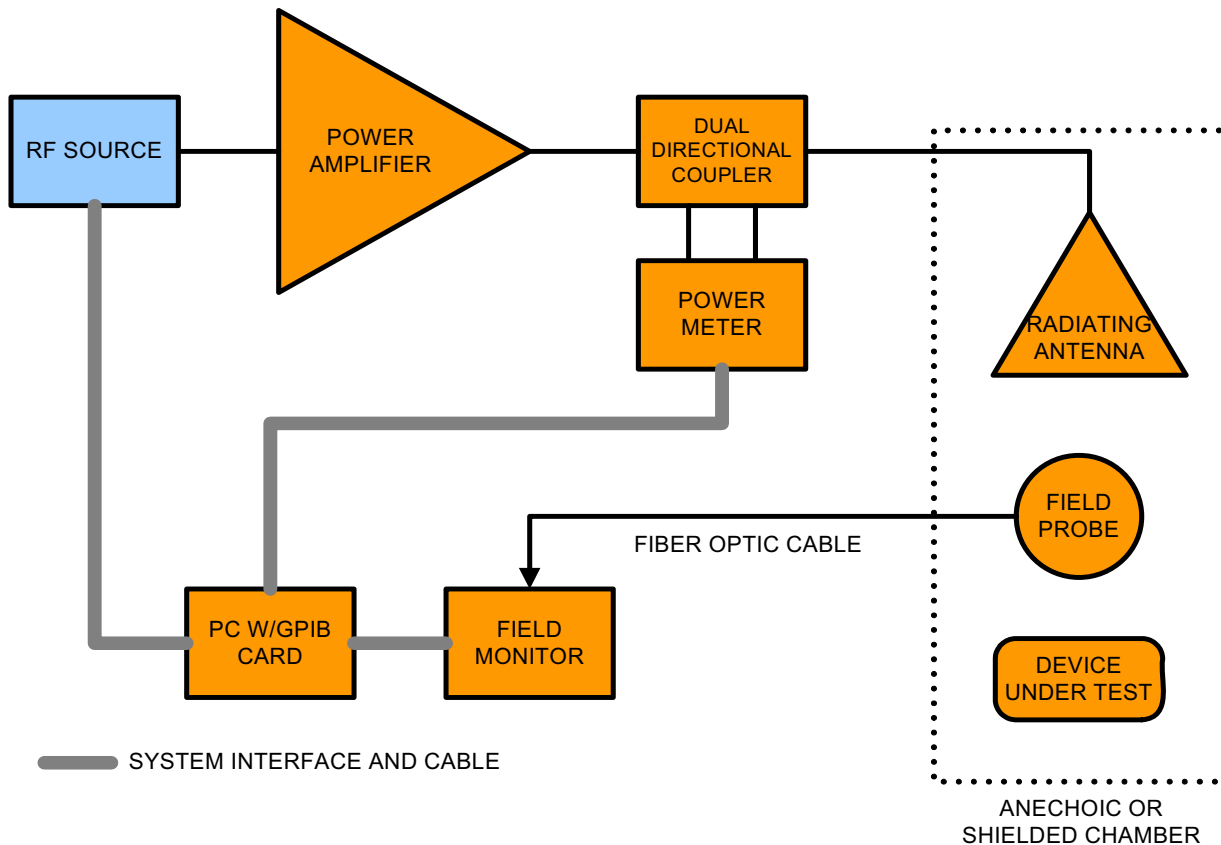

Fully Automated Multi-Band System Full Compliance Radiated Immunity Test Systems

(Use in applications that call for "substitution method" testing)

