

***UNDERSTANDING POWER FACTOR AND
INPUT CURRENT HARMONICS IN
SWITCHED MODE POWER SUPPLIES***

WHITE PAPER: TW0062



Feb 2009 • Alan Gobbi

About the Author

Alan Gobbi

Alan Gobbi is Director of Product Marketing for TDI Power. He gained his B.Sc in Electrical and Electronic Engineering at Manchester University, England. With more than 20 years experience in Power Supplies fulfilling engineering and marketing roles he has a sound understanding of the industry. In his current global role he works closely with engineering and sales to ensure solutions to customers' problems are delivered efficiently and new products are created.

Executive Summary

The proliferation of AC-DC switched mode power supplies has resulted in strict limits being imposed on AC input current power factor and harmonic content. The electronic system designer must take these into account in developing hardware requirements. A sound understanding of typical power factor correction circuit performance and dynamics as a function of line and load will aid in this task.

Introduction

The electrical supply industry has placed requirements on the power factor of electrical equipment for many years. Historically, these requirements were developed around powered equipment consisting of resistive and reactive (inductive or capacitive) loads, which will present varying phase angles between the sinusoidal voltage applied to the load and the current flowing in it. With a purely resistive load the current and voltage are in phase so the real power consumed is just the product of Voltage and Current. However, with reactive elements there will be a phase shift between the current and voltage. For a pure capacitive load the current will lead the voltage by 90 degrees and for a pure inductive load the current will lag the voltage by 90 degrees. With a mixture of resistive and reactive loads the phase angle will be somewhere between +90 and -90 degrees, either leading or lagging. Figure 1 presents a typical reactive load current.

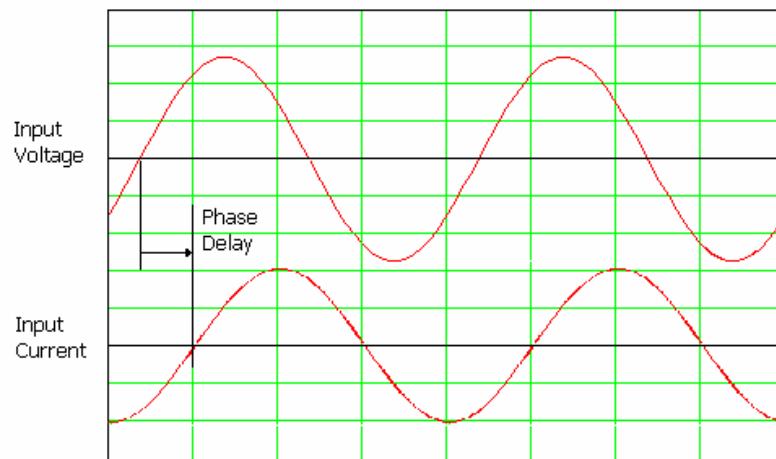

Figure 1 – Reactive Phase Delay

Definition of Power Factor

For a linear load, Power factor is defined as follows:

$$\text{Power Factor (PF)} = \text{Real Power} / (\text{RMS Voltage} \times \text{RMS Current})$$

Power Factor is described as leading for capacitive loads (i.e., current builds up faster than voltage) and lagging for inductive loads (i.e., current builds up slower than voltage). In both these circumstances, the power provided by the utility with less than that which is indicated by a simple multiplication of Volts times Amps. As, among other things, this situation compromises normal conductor sizing algorithms, utility companies often place limits on acceptable power factors for loads (for example <0.8 leading and >0.75 lagging). Financial penalty charges will often be imposed on loads that violate these requirements.

Power Factor with Non-Linear Loads

Several years ago switched mode power supplies became common place. Initially, these used a full wave bridge rectifier connected directly to a large electrolytic capacitor that acts as an energy buffer, as depicted in Figure 2.

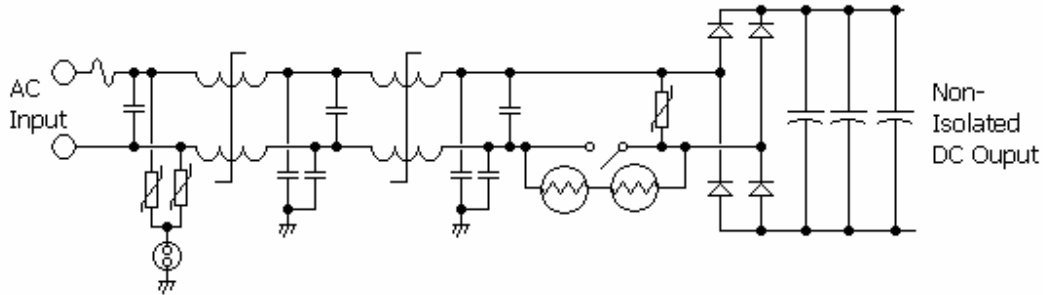

Figure 2 – Power Supply Input Circuit with Bridge Rectifier

AC power is rectified by four diodes from a bipolar wave shape to a unipolar shape. This voltage is then fed to a bank of energy storage capacitors, which maintains the voltage near to its peak value during the low portions of the wave shape. The circuit depicted in Figure 2 also presents some other components that can potentially effect input current harmonics, including EMI filters, inrush limiting circuits (which prevent excessive current when the energy storage capacitors are uncharged), and surge limiting components.

Although there is a large energy storage capacitance in the circuit, it does not result in a significant leading phase angle because of the bridge rectifier. Current flowing to the capacitor is virtually in phase with input voltage, however, as depicted in Figure 3, the current wave shape is not a pure sinusoid.

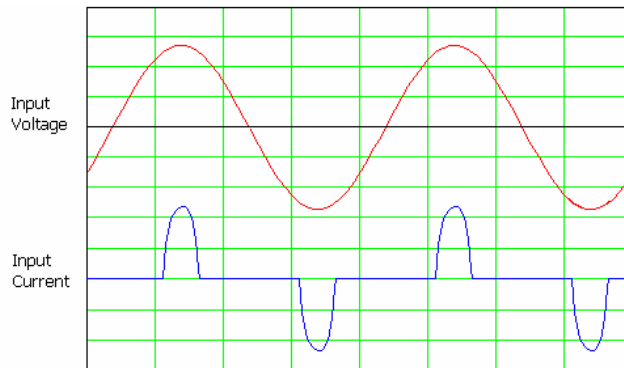

Figure 3 – Input Voltage and Current vs. Time for Bridge Rectifier Circuit

The diode bridge connects the capacitor to the AC source when the voltage is near the peak, resulting in an abridged sinusoidal shaped current wave with current only flowing for about 1 to 2ms every half cycle. Although the current is nominally in phase with the voltage the distorted nature of the current waveform creates potential problems for the AC voltage supply, as described later in this section.

To deal with this type of non linear load the term "apparent power factor" evolved. The inclusion of the word "apparent" implies a non linear load and hence a non-sinusoidal current. This is expressed in the same way as a real power factor, as follows.

$$\text{Apparent Power Factor} = \text{Real Power} / (\text{RMS Voltage} \times \text{RMS Current})$$

For a typical (non-corrected) switched mode power supply the apparent power factor will be approximately 0.7. However, there is no phase angle to speak of as the current and voltage are in phase. Therefore, the apparent power factor cannot be characterized as 0.7 leading or 0.7 lagging. (Note, there may be a small capacitive reactive element due to filter components directly connected to the input before any rectification, but under normal load conditions these have minimal effect on the phase angle of the apparent power factor.)

As shown in Figure 3, the resultant current wave shape from a non-power factor corrected unit is rich in harmonics, the magnitude of which are not accounted for in a simple RMS measurement. If not properly taken into account, these harmonics can cause excessive heating in the AC mains generator and distribution systems. They can be especially harmful to AC UPS systems found in many data centers. In addition to heating effects, excessive harmonics can also create electrical noise that can interfere with the performance of other electronic equipment.

In order to address these problems, the concept of power factor corrected power supplies was developed. These employ either active or passive circuits that tend to fill in the missing portions of the input current waveform, so as to force it to appear purely sinusoidal and in phase with the input voltage. Figure 4 presents a typical power factor correction circuit.

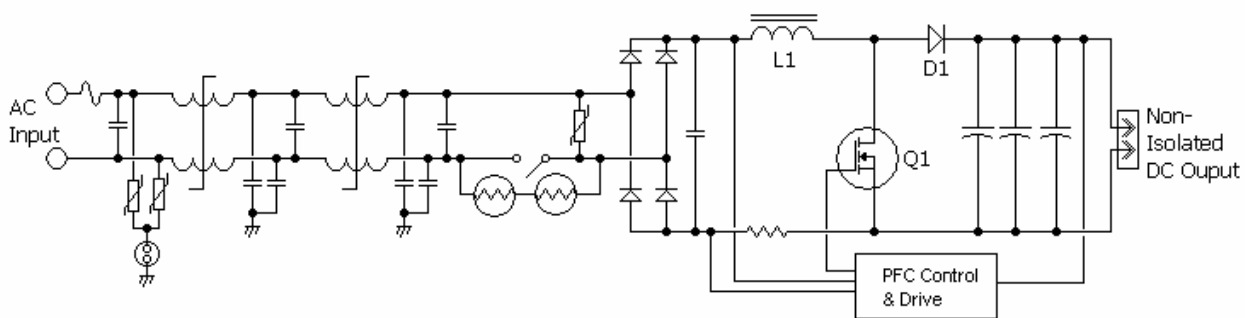

Figure 4 – Active Power Factor Correction Circuit

Inductor L1, diode D1 and switching transistor Q1, along with a control circuit, are added to the simple rectifier circuit from Figure 2 to form a continuous mode boost converter. These operate at

a switching frequency that is well above the input AC frequency (typically around 30 to 50 kHz). Q1 is switched on and off so as to store energy in L1 during Q1's "on" time, and deliver this energy to the energy storage capacitor bank via D1 during Q1's "off" time. The control circuit forces the input current wave shape to follow that of the input voltage, as well as regulating the delivered DC output voltage to a steady value.

Figure 5 depicts the effects of this circuit with the same power being delivered to a power factor corrected supply as was shown in Figure 3 for a non-PFC unit. The input current is now in phase with input voltage and the converter looks like a resistor from the AC line's viewpoint.

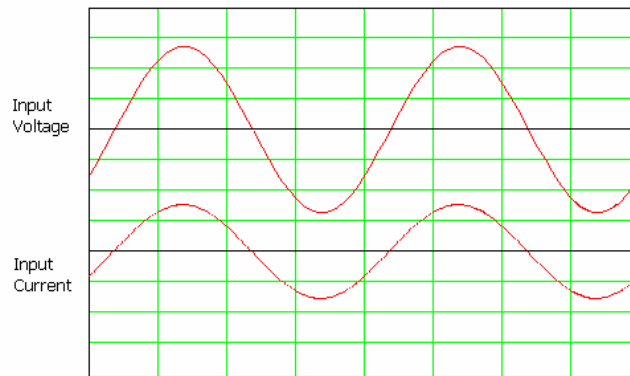

Figure 5 – Input Voltage and Current vs. Time for PFC Circuit

When using power factor corrected power supplies, there are typically two ways of qualifying a product's performance. One is to put a limit on the Apparent Power Factor for loads above a specified minimum power (usually expressed as a percentage of full power capability of the power supply). For example, "the Apparent Power Factor must be > 0.9 for loads $> 50\%$ of full load rating".

A second (and in many ways more rational) method to specify or measure a product is to define absolute maximum limits for current distortion. This is usually expressed as limits for odd harmonics (e.g. 1st, 3rd, 5th, 7th, etc.). This approach does not need any qualifying minimum percentage load and is more relevant to the electric utility as their main interest is to ensure that a particular installation can safely supply any current a load may demand. Regulatory specifications, such as EN61000-3-2/EN61000-3-12 utilize this method.

EN61000-3-2 Harmonic limits

This standard applies to equipment that draws <16A per phase, for equipment that draws >16A and <75A IEC61000-3-12 applies.

Equipment is categorized into one of four classes:

- Class A:** Balanced three phase equipment
Household appliances except items identified by class D
Tools (non portable)
Dimmers for incandescent lamps
Audio Equipment
Everything else that is not in class B, C or D
- Class B:** Portable tools.
Arc welding equipment (non professional)
- Class C:** Lighting equipment
- Class D:** Personal computers
Televisions
>75W, <600W

The limits for class A, which pertain to many switched mode power solutions, are shown in the table below:

Harmonic (n)	Current (A)	Harmonic (n)	Current (A)
3	2.30	2	1.08
5	1.14	4	0.43
7	0.77	6	0.3
9	0.40	$8 \leq n \leq 40$	$0.23 \times 8/n$
11	0.33		
13	0.21		
$15 \leq n \leq 39$	$0.15 \times 15/n$		

Effects of Input Line Voltage, Frequency and Power on Power Factor

Figure 6 presents typical relative input current harmonics for a power factor corrected TDI Power module from the 3rd up to the 39th harmonic for different input voltages and frequencies at full power.

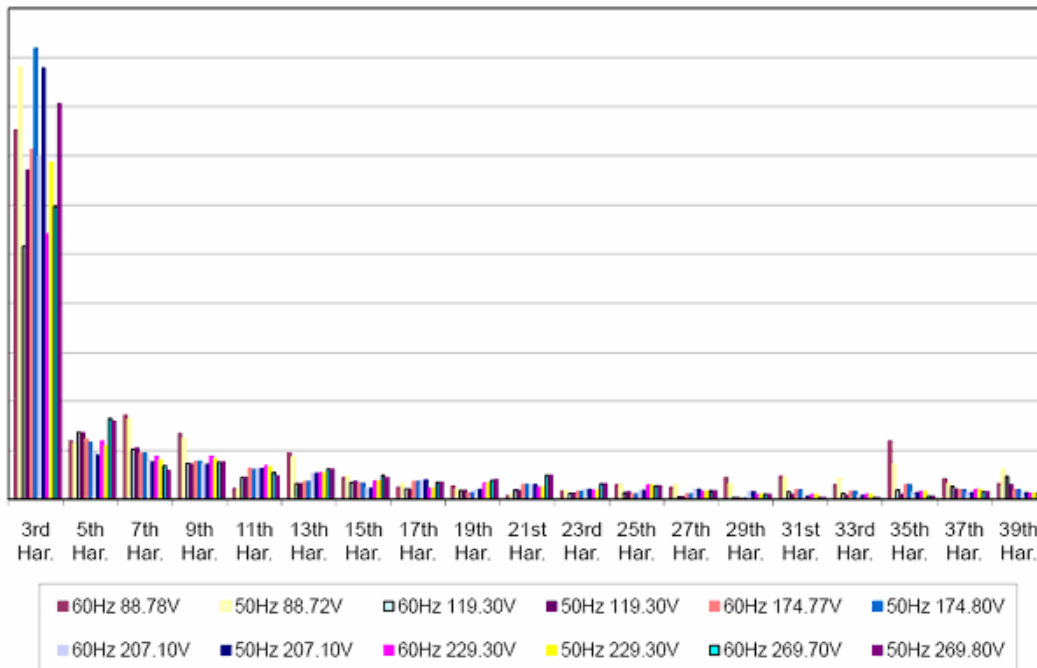
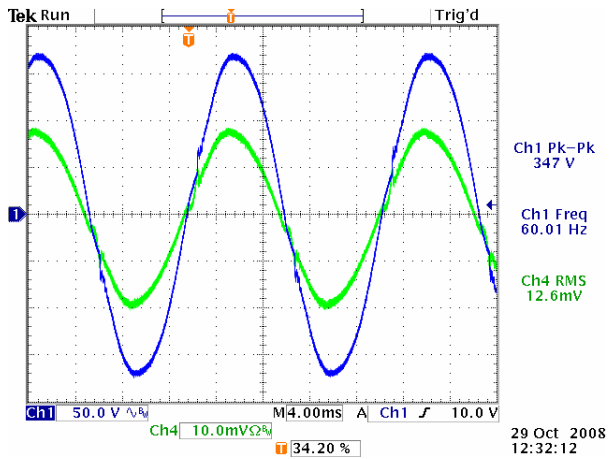

Figure 6 – Relative Input Current Harmonics for a 2700W PFC Power Supply

The apparent power factor range for all these conditions was between 0.986 and 0.999 (essentially unity). As load power reduces, the relative input current distortion increases and at very light loads EMI filter capacitors will begin to create a real phase angle such that the overall power factor (real and apparent) could dip to <0.8.

Figures 7 and 8 present input currents for various power levels for a typical TDI Power Supply. These are shown below the incoming AC voltage waveform and with the same vertical scale factors. Current remains substantially in phase with the voltage and is sinusoidal across a wide power range. At lighter loads more distortion and a slight leading shift in phase can be detected. The final waveform of Figure 8, shown with the vertical current scale amplified, shows the input current with no load on the output. Under these conditions, the across-the-line input filter capacitance begins to dominate and a clear leading phase angle can be seen.

100% load, 120V



40% load, 120V

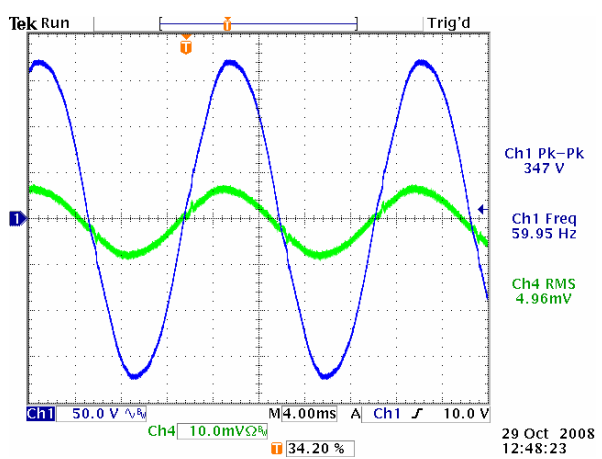

80% load, 120V

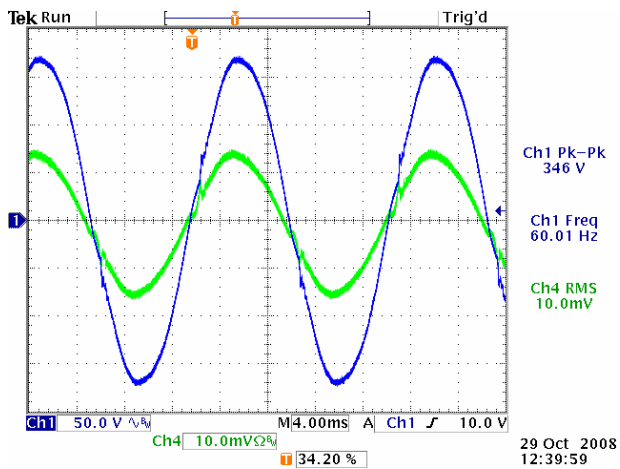

20% load, 120V

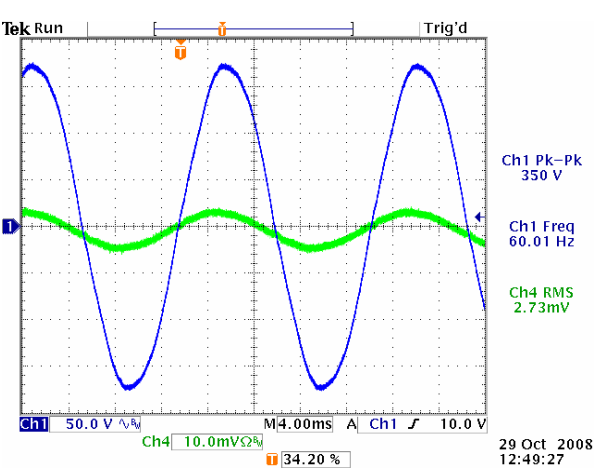

60% load, 120V

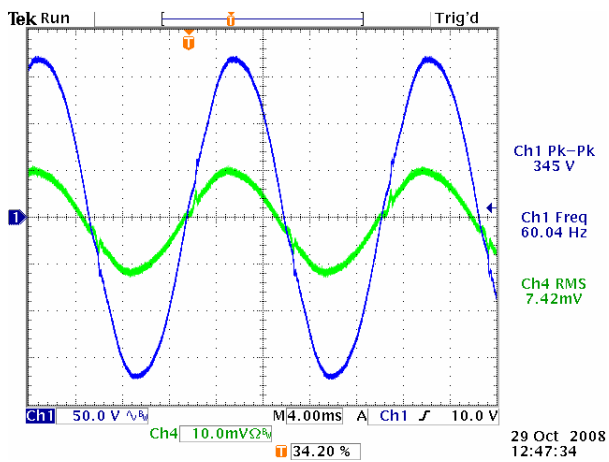
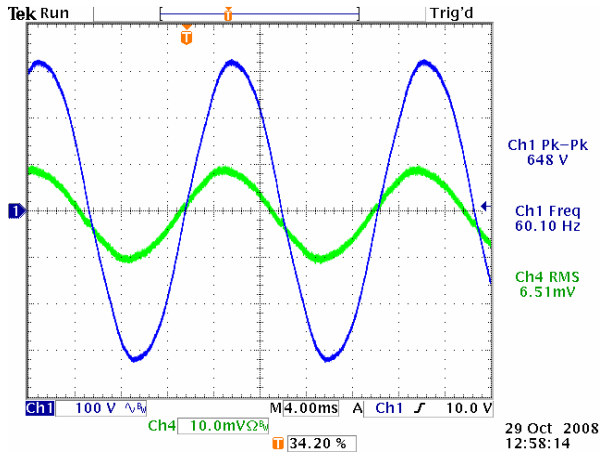
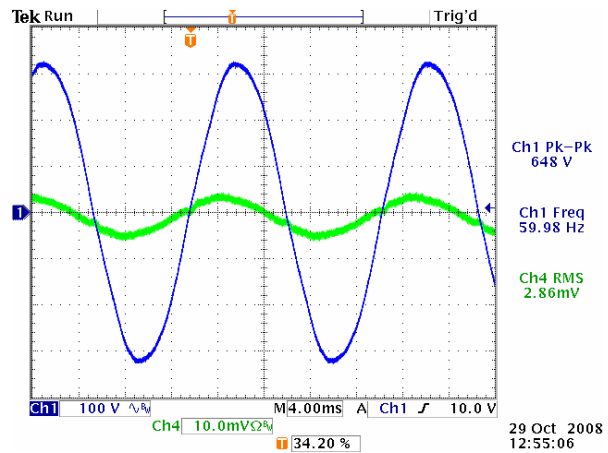

Figure 7 – Input Voltage and Current Waveforms for 120VAC Input

100% load, 230V



40% load, 230V



80% load, 230V

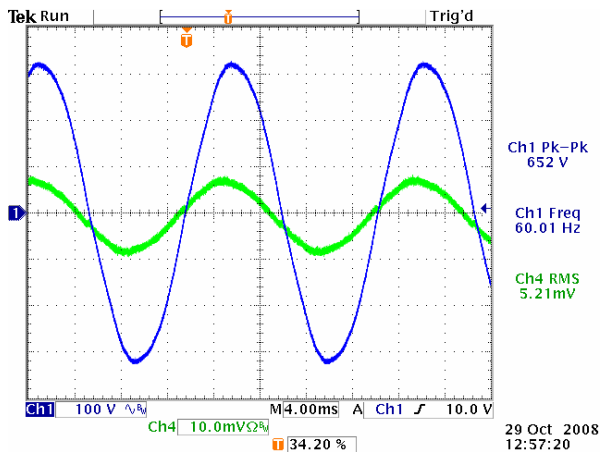

20% load, 230V

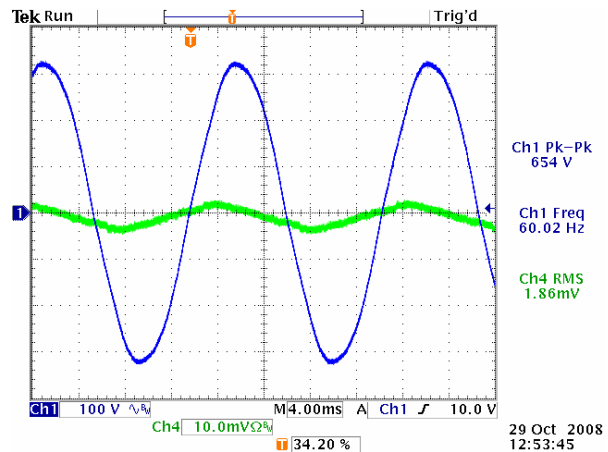

60% load, 230V

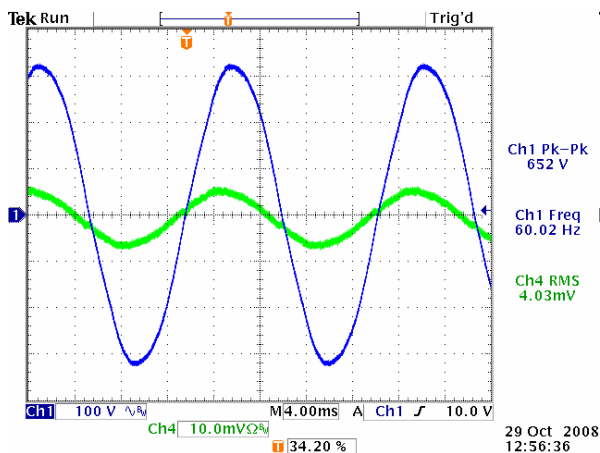

0% load, 230V (Note 10X higher scale factor)

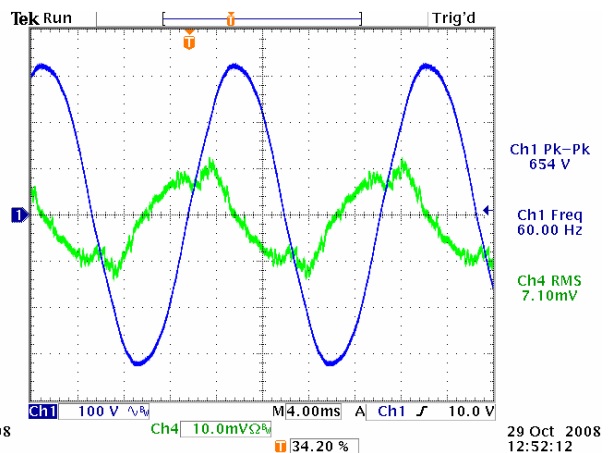

Figure 8 - Input Voltage and Current Waveforms for 230VAC Input

Conclusion

Power Factor Correction mitigates any deleterious effects that input current harmonics might present to system AC feeds. Specifications relating to switched mode loads are most realistic when a range of absolute current harmonics is specified (independent of any power demand). Alternatively, if there is desire to specify power factors for all load types, this should include a leading limit, a lagging limit and an apparent PF limit with a qualifying minimum load condition.